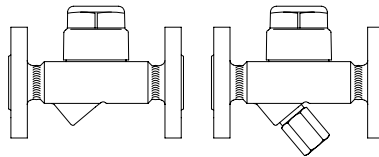


Thermodynamic steam trap

Thermodynamic steam trap

ANSI150 / 300

- with flanges (Fig. 640/641....1)
- with screwed sockets (Fig. 640/641....2)
- with socket weld ends (Fig. 640/641....3)
- with butt weld ends (Fig. 640/641....4)



Forged steel
Stainless steel
Fig. 640/641 (Y)

Page 2

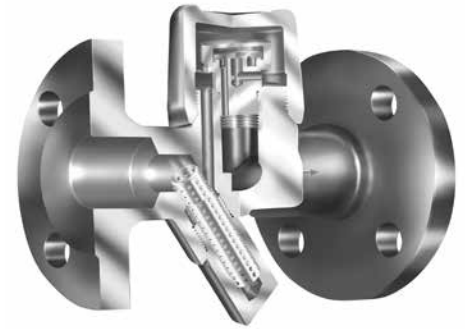
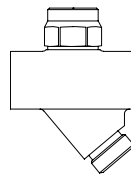


Fig. 641....1

Thermodynamic steam trap

ANSI 400

- with screwed sockets (Fig. 641....2)
- with socket weld ends (Fig. 641....3)



Stainless steel
Fig. 641 (Y)

Page 4

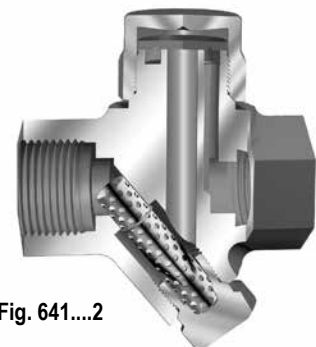
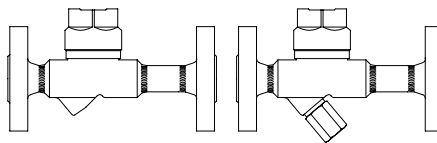


Fig. 641....2

Thermodynamic steam trap

ANSI 600

- with flanges (Fig. 640/641....1)
- with socket weld ends (Fig. 640/641....3)
- with butt weld ends (Fig. 640/641....4)



Forged steel
Fig. 640/641 (Y)

Page 6

Features:

- For discharging of slight to highly sub-cooled condensate
- Intermittent mode of operation
- Robust and resistant to water-hammer
- Integrated non return protection
- Constructions:
 - With inside strainer - Fig. 640
 - with outside strainer - Fig. 641 (Y)
- Optimized design for quick installation
- Gasket-free sealing of the screwed cap
- Installation in any position
- Heat chamber minimizes the impact of weather conditions on the trap's performance (not for ANSI400)
- Replaceable controller-unit
- Pressure test acc. to API 598
- CRN approved

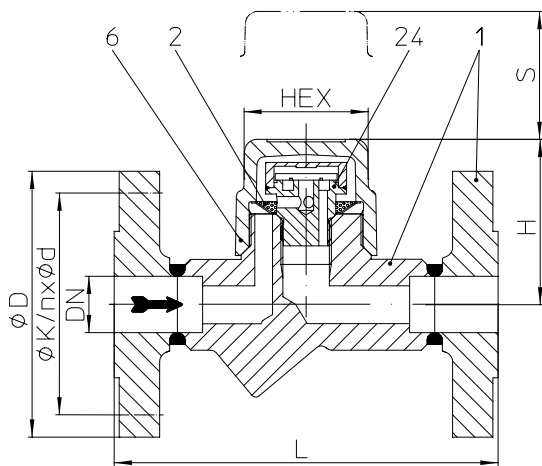
Thermodynamic steam trap (Forged steel, Stainless steel)


Fig. 640....1 with flanges

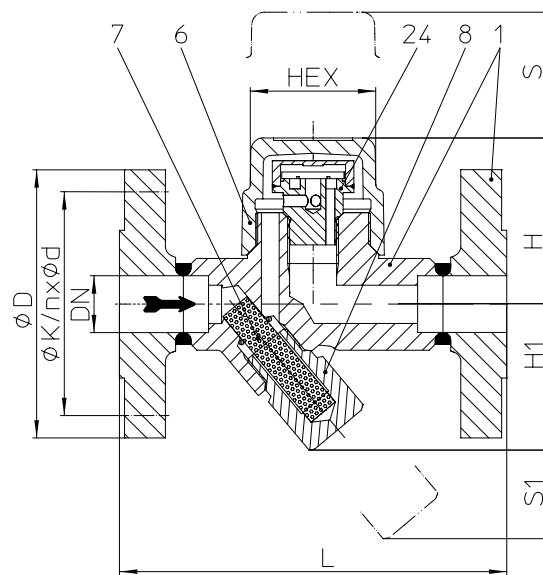


Fig. 641....1 with flanges

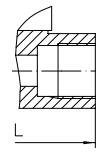


Fig. 640/641...2 with screwed sockets

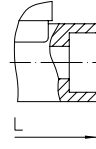


Fig. 640/641...3 with socket weld ends

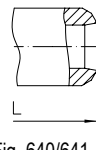


Fig. 640/641...4 with butt weld ends

Figure	Nominal pressure	Material	NPS	Operating pressure PS	Inlet temperature TS	Allow. differential pressure ΔPMX	Perm. pressure ratio
42.640	ANSI150	SA105	1/2" - 1"	13 barg	225 °C	32 bar	Back pressure / Inlet pressure: ≤ 0,8 barg min. operating pressure: 0,7 barg
42.641 (Y)				5,5 barg	427 °C		
45.640	ANSI300	SA105	1/2" - 1"	32 barg	411 °C		
45.641 (Y)				28 barg	427 °C		
52.640	ANSI150	SA182 F321	1/2" - 1"	13 barg	225 °C		
52.641 (Y)				2,4 barg	510 °C		
55.640	ANSI300	SA182 F321	1/2" - 1"	32 barg	377 °C		
55.641 (Y)				27 barg	510 °C		

DIN/EN-Constructions refer to data sheet CONA®TD

Types of connection		Other types of connection on request.
<ul style="list-style-type: none"> Flanges1 _____ acc. to ASME B16.5 Screwed sockets2 ___ NPT thread acc. to ANSI B1.20.1 or Rp thread acc. to DIN EN 10226-1 Socket weld ends3 ___ acc. to ASME B16.11 Butt weld ends4 _____ ASME B16.25 (Note restriction on operating pressure / inlet temperature depending to design!) 		
Features		
<ul style="list-style-type: none"> Thermodynamic steam trap with replaceable controller-unit and cap with heat chamber wich minimize the effects from the weather conditions to the function of the trap such as low ambient temperatures, rain, wind, etc.. Intermittent mode of operation Heat chamber minimizes the impact of weather conditions on the trap's performance Robust and resistant to water-hammer 		<ul style="list-style-type: none"> Integrated non return protection With inside strainer - BR640 / with outside strainer - BR641 (Y) Installation in any position Optimized design for quick installation Maintenance simplified due to screwed cap without sealing
Options		(Design refer to page 3)
<ul style="list-style-type: none"> Outside strainer with blow down valve (Pos. 46) 		

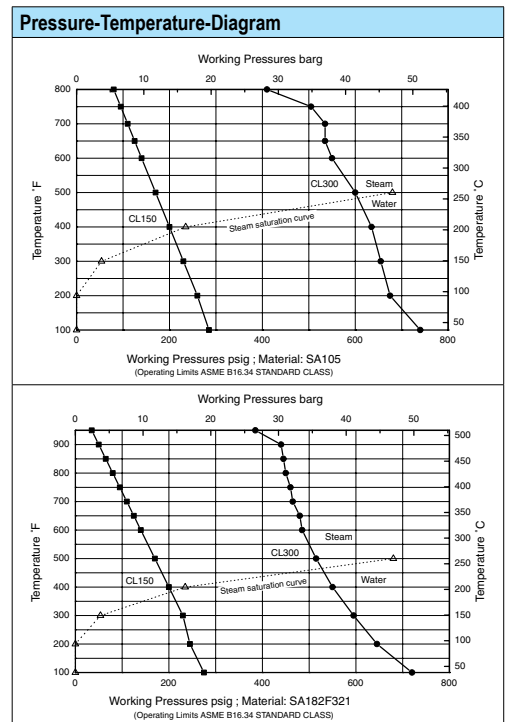
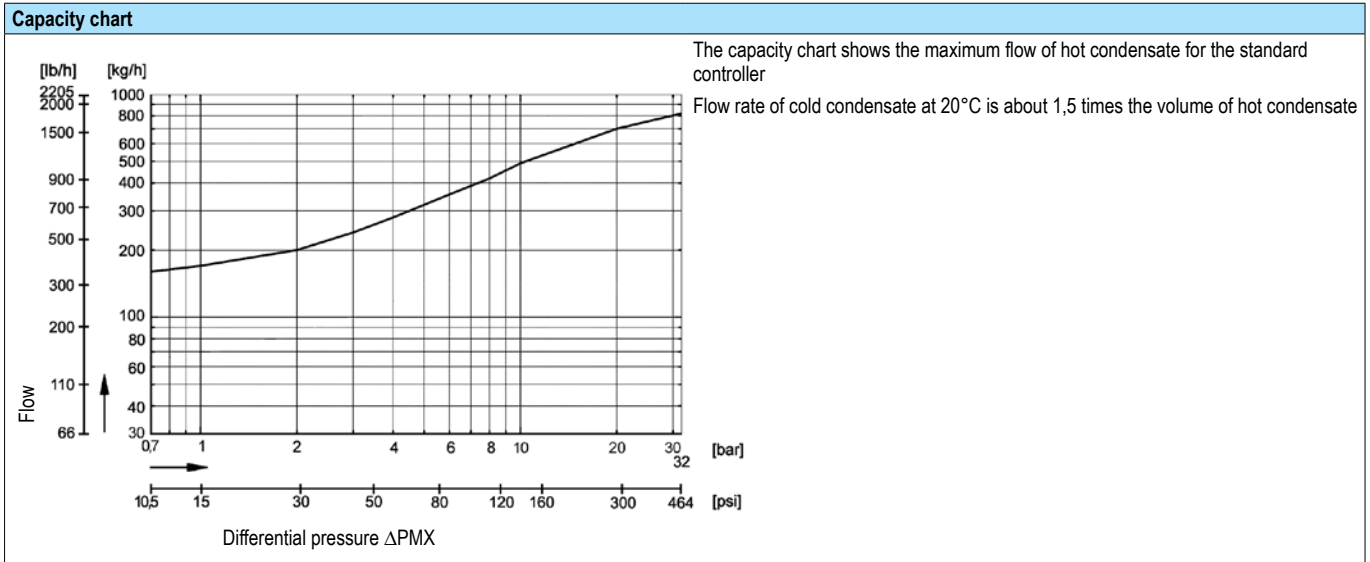
Types of connection	Flanges			Screwed sockets Socket weld ends			Butt weld ends			
	NPS	1/2"	3/4"	1"	1/2"	3/4"	1"	1/2"	3/4"	1"
Face-to-face acc. to data sheet resp. customer request										
L	(mm)	150	150	160	95	95	95	250	250	250
Dimensions Standard-flange dimensions refer to page 9										
H	(mm)	65	65	74	65	65	74	65	65	74
H1	(mm)	62	62	55	62	62	55	62	62	55
S	(mm)	40	40	40	40	40	40	40	40	40
S1	(mm)	24	24	24	24	24	13	24	24	24
HEX	(mm)	50	50	50	50	50	50	50	50	50
Weights										
(approx.)	(kg)	2,7	3,3	3,7	1,4	1,3	1,8	1,8	1,9	2

Parts				
Pos.	Sp.p.	Description	Fig. 42.640/641; 45.640/45.641	Fig. 52.640/641; 55.640 / 55.641
1		Body	SA105	SA182F321
2	x	Strainer	SA240Gr.304	
6		Cap	SA105	SA276Gr.321
7	x	Strainer	SA240Gr.304	
8		Strainer plug	SA276Gr.321	
24	x	Controller, cpl.	AISI440	
46	x	Blow down valve, cpl.	SA276Gr.321	
└ Spare parts				

Information / restriction of technical rules need to be observed!

Resistance and fitness must be verified (contact manufacturer for information, refer to Product overview and Resistance list).

Operating and installation instructions can be downloaded at www.ari-armaturen.com.



Thermodynamic steam trap (Stainless steel)

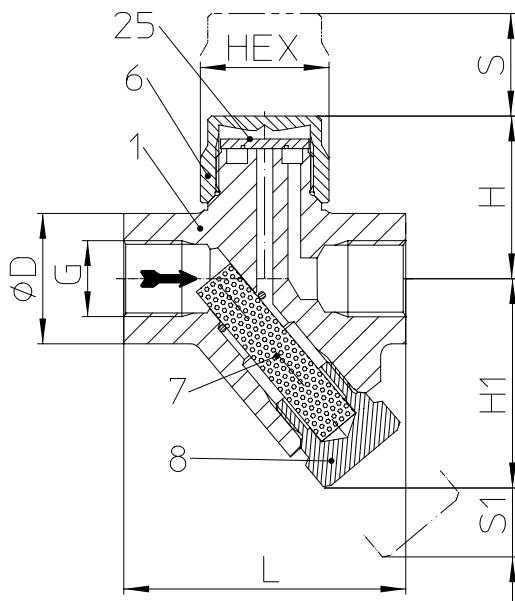


Fig. 641....1 with screwed sockets

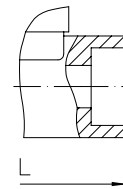

 Fig. 640/641....3
 with socket weld ends

Figure	Nominal pressure	Material	NPS	Operating pressure PS	Inlet temperature TS	Allow. differential pressure ΔPMX	perm. pressure ratio
56.641 (Y)	ANSI400	A743CA40	3/8" - 3/4"	42 barg	402 °C	42 bar	Back pressure / Inlet pressure: $\leq 0,8$ barg min. operating pressure: 0,7 barg
		SA182F6A	1"				

DIN/EN-Constructions refer to data sheet CONA®TD

Types of connection Other types of connection on request.

- Screwed sockets2 ___ NPT-Thread acc. to ASME B1.20.1 or Rp-Thread acc. to DIN EN 10226-1 - (NPS 3/8" - 1")
- Socket weld ends3 ___ acc. to ASME B16.11 - (NPS 1/2"-3/4")

Features

- Thermodynamic steam trap of stainless steel for the condensate-discharge from all kinds of steam systems
- Intermittent mode of operation
- Robust and resistant to water-hammer
- Integrated non return protection
- With outside strainer
- Installation in any position
- Optimized design for quick installation
- Maintenance simplified due to screwed cap without sealing

Types of connection	Screwed sockets (3/8" - 1")			--
	--	Socket weld ends (1/2"-3/4")		
NPS	3/8"	1/2"	3/4"	1"

Face-to-face acc. to data sheet resp. customer request				
L	(mm)	78	78	95

Dimensions					Standard-flange dimensions refer to page 9	
H	(mm)	47	47	50	59	
H1	(mm)	56	56	56	61	
S	(mm)	20	20	20	20	
S1	(mm)	45	45	45	45	
HEX	(mm)	32	32	32	41	

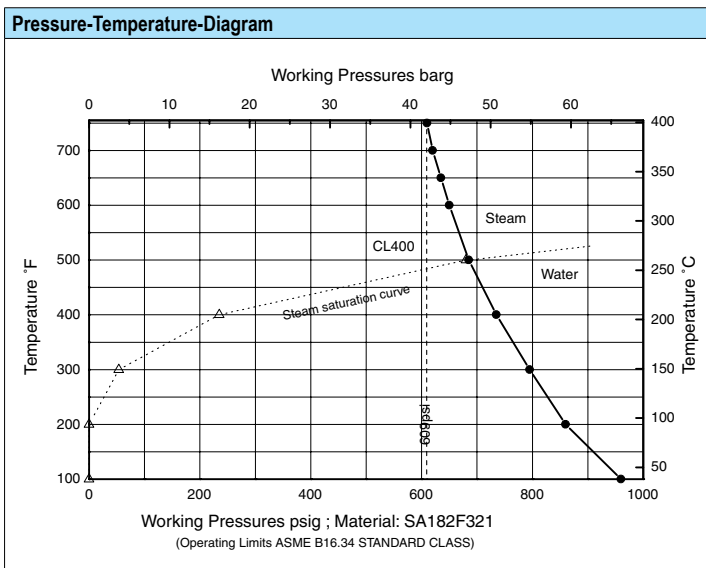
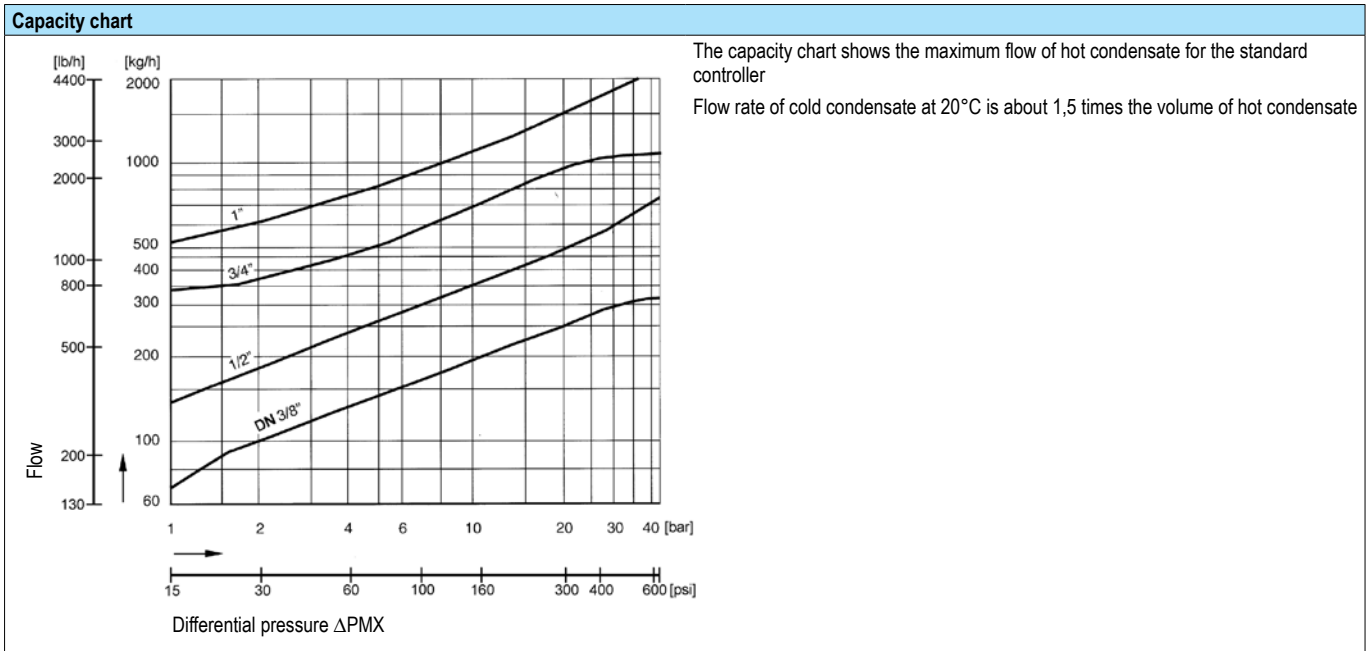
Weights						
(approx.)	(kg)	0,8	0,8	0,8	0,9	

Parts				
Pos.	Sp.p.	Description	Fig. 56.641	
			NPS 3/8" - 3/4"; DN10-20	NPS 1"; DN25
1		Body	A743 CA40	SA182F6A
6		Cap	SA276Gr.321	
7	x	Strainer	SA240Gr.304	
8		Strainer plug	SA276Gr.321	
25	x	Disc	AISI440	
L Spare parts				

Information / restriction of technical rules need to be observed!

Resistance and fitness must be verified (contact manufacturer for information, refer to Product overview and Resistance list).

Operating and installation instructions can be downloaded at www.ari-armaturen.com.



Thermodynamic steam trap (High temperature steel)

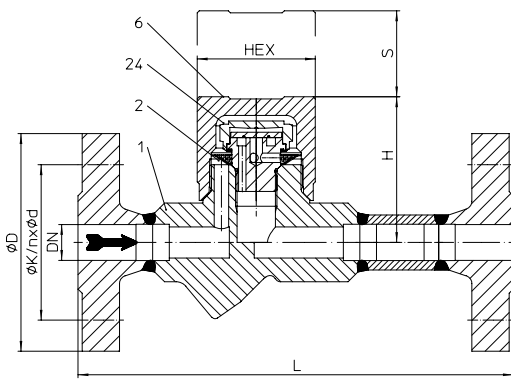


Fig. 640....1 with flanges

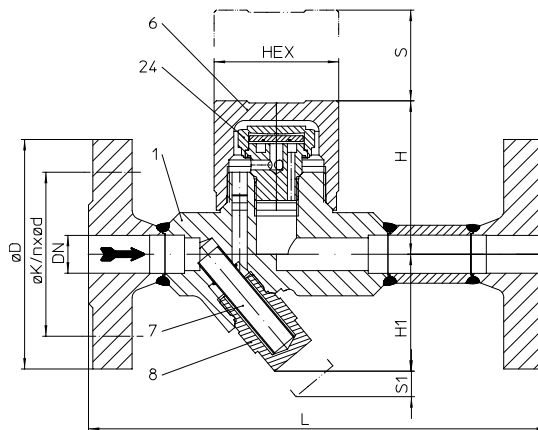


Fig. 641....1 with flanges

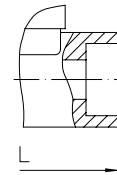


Fig. 640/641....3 with socket weld ends

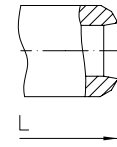


Fig. 640/641....4 with butt weld ends

Figure	Nominal pressure	Material	NPS	Operating pressure PS	Inlet temperature TS	Allow. differential pressure ΔPMX	perm. pressure ratio
47.640 47.641 (Y)	ANSI600	SA105	1/2" - 1"	42 barg	427 °C	42 bar	Back pressure / Inlet pressure: ≤ 0,8 barg min. operating pressure: 0,7 barg

DIN/EN-Constructions refer to data sheet CONA®TD

Types of connection		Other types of connection on request.
<ul style="list-style-type: none"> Flanges1 _____ acc. to acc. to ASME B16.5 Socket weld ends3 ___ acc. to ASME B16.11 Butt weld ends4 _____ ASME B16.25 (Note restriction on operating pressure / inlet temperature depending to design!) 		
Features		
<ul style="list-style-type: none"> Thermodynamic steam trap with replaceable controller-unit and cap with heat chamber wich minimize the effects from the weather conditions to the function of the trap such as low ambient temperatures, rain, wind, etc.. Intermittent mode of operation Heat chamber minimizes the impact of weather conditions on the trap's performance Robust and resistant to water-hammer 		<ul style="list-style-type: none"> Integrated non return protection With inside strainer - BR640 / with outside strainer - BR641 (Y) Installation in any position Optimized design for quick installation Maintenance simplified due to screwed cap without sealing

Types of connection	Flanges			Socket weld ends			Butt weld ends ²⁾		
	NPS	1/2"	3/4" ¹⁾	1"	1/2"	3/4"	1"	1/2"	3/4"

¹⁾ acc. to DIN EN 1092-1

²⁾ Please indicate dimension of the tube when ordering

Face-to-face acc. to data sheet resp. customer request										
L	(mm)	210	210	230	95	95	95	250	250	250

Dimensions										
Standard-flange dimensions refer to page 9										
H	(mm)	65	65	74	65	65	74	65	65	74
H1	(mm)	62	62	55	62	62	55	62	62	55
S	(mm)	40	40	40	40	40	40	40	40	40
S1	(mm)	24	24	24	24	24	13	24	24	24
HEX	(mm)	50	50	50	50	50	50	50	50	50

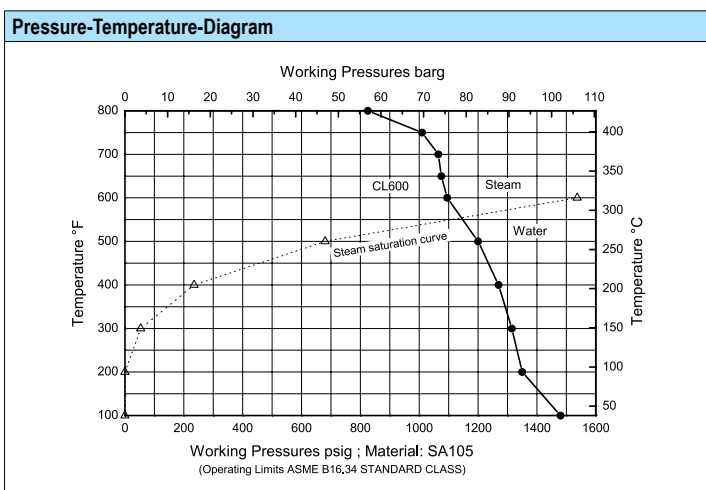
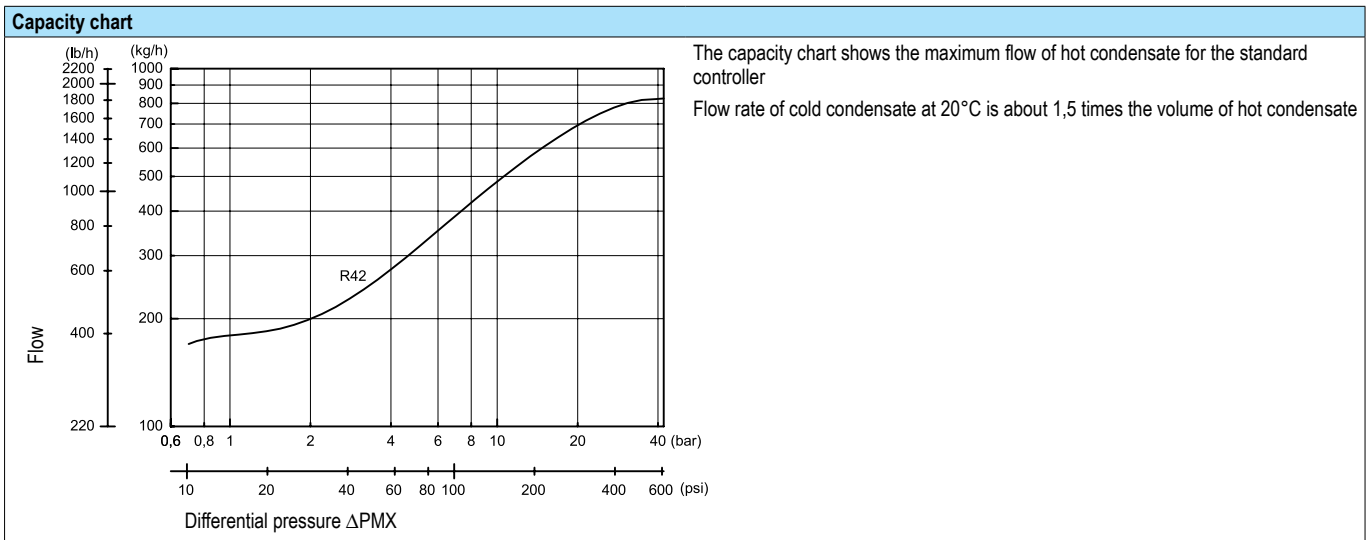
Weights										
(approx.)	(kg)	3,7	5,2	6,6	1,3	1,2	1,7	1,8	1,9	2,0

Parts				
Pos.	Sp.p.	Description	Fig. 47.640	Fig. 47.641
1		Body	SA105	
2	x	Strainer	SA240Gr.304	--
6		Cap	SA105	
7	x	Strainer	--	SA240Gr.304
8		Strainer plug	--	SA276Gr.321
24	x	Controller, cpl.	AISI440	
		L Spare parts		

Information / restriction of technical rules need to be observed!

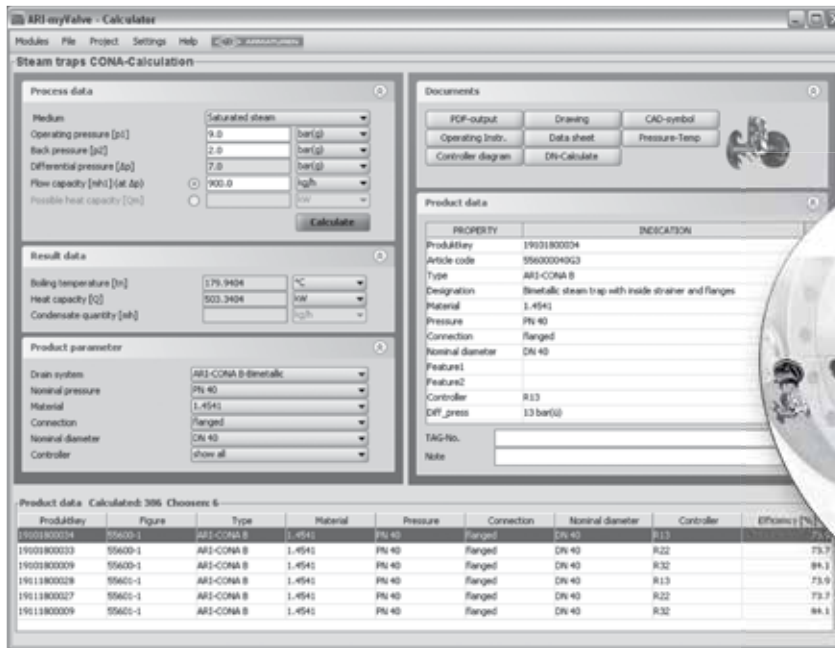
Resistance and fitness must be verified (contact manufacturer for information, refer to Product overview and Resistance list).

Operating and installation instructions can be downloaded at www.ari-armaturen.com.



myValve® - Ihr VAlve Sizing-Program.

myValve is a powerful software tool that not only helps you size your system components; it also gives you instant access to all other data about the selected product, such as order information, spare parts drawings, operating instructions, data sheets, etc., whenever you need it.


myValve - VAlve Sizing-Program
Contents:
Module ARI-Steam trap CONA-Calculation

- Sizing (calculation of steam trap systems with given flow capacity or heat capacity)
- Calculation of nominal diameter acc. to given pressure, condensate quantity, condensate sub-cooling and speed

Media:

- Steam (saturated and superheated)
- Compressed air

Special Features

- Project administration of the calculation and product data incl. spare part drawings concerning to project and tag number
- Direct output or calculation and product data in PDF format
- Product data could be taken for a direct order
- SI- and ANSI-units with direct conversion to another databank
- Settings with over pressure or absolute pressure
- All ARI products are integrated in one databank
- Direct access concerning to the product on data sheets, operating instructions, pressure-temperature-diagram and spare part drawings
- Operation in company networks possible (no complex installations on individually PC's necessary)
- Extensive catalogue extending over several product groups

System Requirements:

Windows operating systems, Linux, etc.

Informations about pipe welding
Welding groove acc. to ASME B16.25

The material used for ARI valves with butt weld ends are:

	SA105	
	A743 CA40	acc. to ASTM A743/A743M-98a
Note:	SA182F6A	

Note restriction on operating pressure / inlet temperature depending to design!

Due to our experience, we recommend to apply an electric welding process.

Because of the different material compositions and wall thickness of the steam traps and the pipe gas welding shall not be applied. Quenching cracks and coarse grain structure may develop.

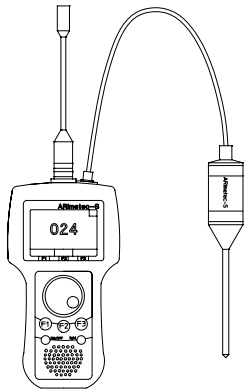
Steam traps with socket-weld ends shall only be welded by arc welding (welding process 111 acc. to DIN EN 24063).

If during the time of warranty others than the manufacturer or by the manufacturer authorized persons are interfering in the product and/or the setting, the right of claim for warranty will lapse!

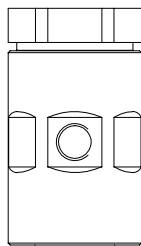
Standard-flange dimensions acc. to ASME B16.5

NPS			1/2"	3/4"	1"
ANSI150	ØD	(mm)	89	99	108
	ØK	(mm)	60	70	79
	n x Ød	(mm)	4 x 16	4 x 16	4 x 16
ANSI300	ØD	(mm)	95	117	124
	ØK	(mm)	66,5	82,5	89
	n x Ød	(mm)	4 x 16	1 4 x 9	4 x 19
ANSI600	ØD	(mm)	95	117	127
	ØK	(mm)	67	83	89
	n x Ød	(mm)	4 x 16	4 x 19	4 x 19

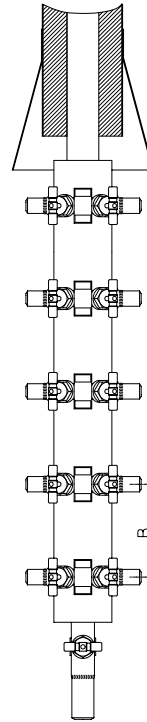
Selection criteria:	Example for order data:
<ul style="list-style-type: none"> • Steam pressure • Back pressure • Quantity of condensate • Nominal diameter / pressure • Type of connection • Controller • Material • Place of service or kind of steam consumer 	<p>Thermodynamic steam trap CONA® TD, Fig. 640, ANSI300, NPS 1/2", SA105, with screwed sockets, Face-to-face dimension 95 mm</p>



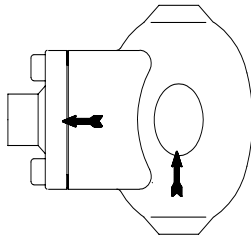
Multifunction tester ARImetec®-S



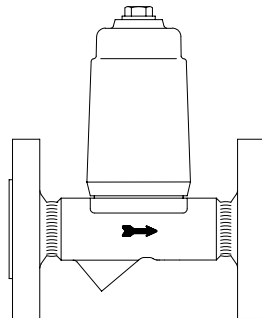
Vacuum breaker
Fig. 655



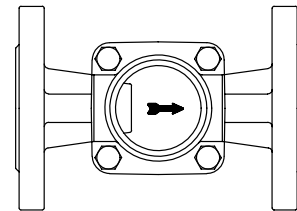
CODI®S with gland packing Fig. 671/672;
CODI®B with bellows seal, maintenance-free Fig. 675/676



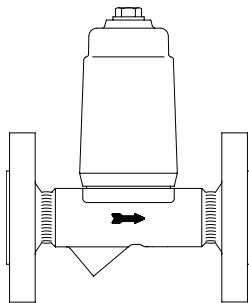
Automatic air vent for liquid systems
Fig. 656



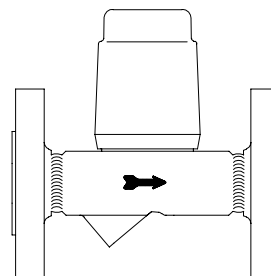
Condensate discharge temperature limiter
Fig. 645/647



Flow indicator
Fig. 660/661



Return temperature limiter
Fig. 650



Liquid drainer
Fig. 665

(Further informations about the accessories can be found in the appropriate data sheets.)